

COLEMAN *Spas*™

OWNER'S MANUAL

CONTENTS

Important Safety Instructions	2
Spa System Components	4
Spa Installation	5
Electrical Information	6
120 Volt or 240 Volt Installation	6/7
Start—Up Procedures	7
Equipment Control Panel	9

Operating Instructions	9/18
Jet & Therapy Control	16
Maintenance/Priming	17/18
Hot Water Guide	22
Spa Soaking Guidelines	21
Wiring Diagrams	23/24

OWNER'S RECORD

Date Purchased _____

Purchased From _____

Installed By _____

Serial Number _____ Model _____

SAVE THIS INFORMATION FOR FUTURE USE

IMPORTANT SAFETY INSTRUCTIONS

CAUTION: RISK OF ELECTRICAL SHOCK. READ AND FOLLOW ALL INSTRUCTIONS

SAVE THESE INSTRUCTIONS

1. Take special care to make sure your spa has a level, solid foundation. You must install your spa to provide drainage away from the electrical component compartment.
2. The very young, or aged, those with illness, heart conditions or under doctor's care should not use the spa unattended. Infants should not be permitted in the spa at water temperatures over 100°F.
3. To reduce the risk of injury:
 - A. The water in a spa or hot tub should never exceed 40°C (104°F). Water temperatures between 38°C (100°F) and 40°C (104°F) are considered safe for a healthy adult. Lower water temperatures are recommended for extended use (exceeding 10-15 minutes) and for young children.
 - B. Since excessive water temperatures have a high potential for causing fetal damage during the early months of pregnancy, pregnant or possibly pregnant women should limit spa or hot tub water temperatures to 38°C (100°F).
 - C. Before entering a spa or hot tub, the user should measure the water temperature with an accurate thermometer since the tolerance of water temperature-regulating devices may vary as much as ±3°C (5°F).
 - D. The use of alcohol, drugs, or medication before or during spa or hot tub use may lead to unconsciousness with the possibility of drowning.
 - E. Persons suffering from obesity or with a medical history of heart disease, low or high blood pressure, circulatory system problems, or diabetes should consult a physician before using a spa or hot tub.
 - F. Persons using medication should consult a physician before using a spa or hot tub since some medication may induce drowsiness while other medication may affect heart rate, blood pressure, and circulation.
4. **DANGER: To reduce the risk of injury, do not permit children to use this product unless they are closely supervised at all times.**
5. Special care should be taken when using the spa and consuming alcoholic beverages. Alcohol, drugs, and some medications affect a person's ability to withstand the high temperatures and could produce dangerous effects.
6. Do not use electrical appliances such as television, radio, lights, cooking devices, or telephones within 10 feet of the spa while the spa is being used. Lighting fixtures must not be located directly above or within 10 feet of the spa. Lighting fixtures located within 20 feet of the spa must be on a circuit protected by a ground fault circuit interrupter (GFCI).
7. Do not use an extension cord to power your spa. This may cause an electric shock or may permanently damage your portable spa and may void the warranty.
8. Do not plug in the spa unless it is filled with water to the normal water level 6" below the top of the spa lip. Starting the spa when the water level is low can damage the circulation pump and heater and could cause a fire.
9. Keep your water chemistry correctly balanced. Untreated spa water will cause problems with your spa and support equipment. Maintaining the correct balance is simple if you just take time to read your test kit instructions and check your water regularly. (Damage to your spa or equipment due to improper water balance is not covered by warranty.)
10. Clean your filter about once a month if you use the spa frequently. Do not allow people in your spa with suntan lotion or other oils on their skin. It will coat and inhibit efficient filter operation.
11. Do not allow hair and clothing within twelve inches (12") of skimmers, suction fittings or drains at any time. Persons with long hair should either secure hair to a minimum length or wear a bath cap.
DANGER - To reduce risk of injury, do not remove suction grate or cover.

12. The wet surface of the spa is slippery. Enter and exit the spa slowly and cautiously.
13. After use, immediately replace your cover. Using a spa cover will save utility costs, keep your spa cleaner and provide added safety when the spa is left unattended. Moreover, since the spa stays warmer, it heats up faster and is more convenient to use. Note: Spa cover is not capable of supporting weight of people. Do not allow anyone to stand on the cover.
14. It is necessary to have the equipment panel door properly in place to operate the spa.
15. Do not lift the spa from the top edge of the equipment panel. This could damage the spa cabinet. Always lift the spa from the bottom!
16. (Cord-connected units) Connect power cord only to a properly grounded, dedicated receptacle.
17. **Cord connected units with optional GFCI.** Check GFCI for proper operation prior to use. This appliance is provided with a ground fault circuit interrupter located on the cord. Before each use, push the test button. The reset button should appear. Push the reset button. The unit should now operate normally. If the interrupter does not perform in this manner, a ground current is flowing indicating the possibility of an electric shock. Disconnect the power until the fault has been identified and corrected.
18. **MAKE SURE YOU HAVE A LICENSED ELECTRICIAN MAKE THE FINAL ELECTRICAL CONNECTIONS.**
19. (Cord-connected units) Do not bury power cord.
20. **WARNING - To reduce the risk of electrical shock, replace damaged cord immediately.**
21. **DANGER - RISK OF ELECTRIC SHOCK.** Install at least 5 feet (1.5 meters) from all metal surfaces. (A spa may be installed within 5 feet of metal surfaces if each metal surface is permanently connected by a minimum No. 8 AWG (8.4 mm²) solid copper conductor attached to the wire connector on the terminal box that is provided for this purpose.)

IMPORTANT SAFETY INSTRUCTIONS

CAUTION: RISK OF ELECTRICAL SHOCK. READ AND FOLLOW ALL INSTRUCTIONS

SAVE THESE INSTRUCTIONS

1. **WARNING - RISK OF CHILD DROWNING**
Extreme caution must be exercised to prevent unauthorized access by children. To avoid accidents, ensure that children cannot use a spa or hot tub unless they are supervised at all times.
2. The electrical supply for this product must include a suitably rated switch or circuit breaker to open all ungrounded supply conductors to comply with Section 422-20 of the National Electrical Code, ANSI/NFPA 70-1987. This disconnecting means must be readily accessible for operation but installed at least 5 feet (1.5 meters) from the spa tub water.
3. A pressure wire connector is attached to the control box inside this spa to permit connection of a minimum No. 8 AWG (8.4 mm²) solid copper ground bonding conductor between this point and any metal equipment, metal electrical boxes or fixtures, metal water pipes or conduits that are within 5 feet (1.5 meters) of the spa as required to comply with local code requirements.

100 Series

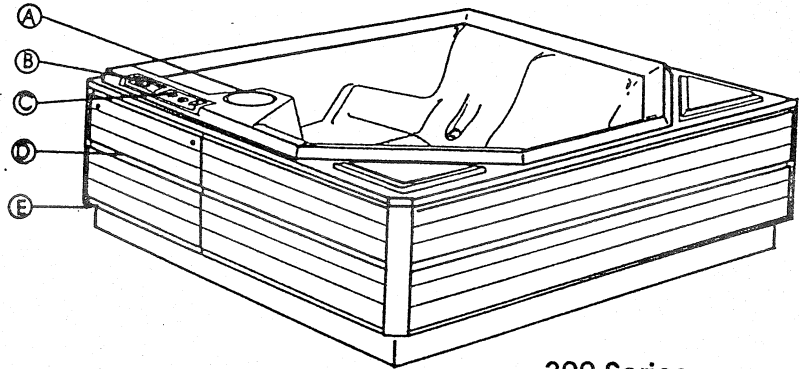
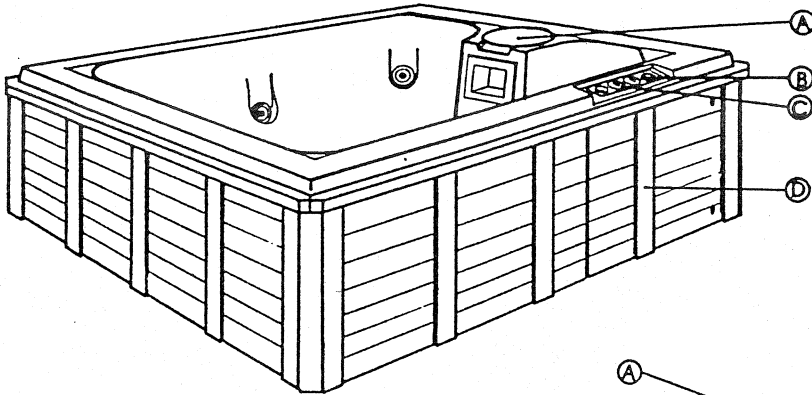

300 Series

SPA SYSTEM COMPONENTS

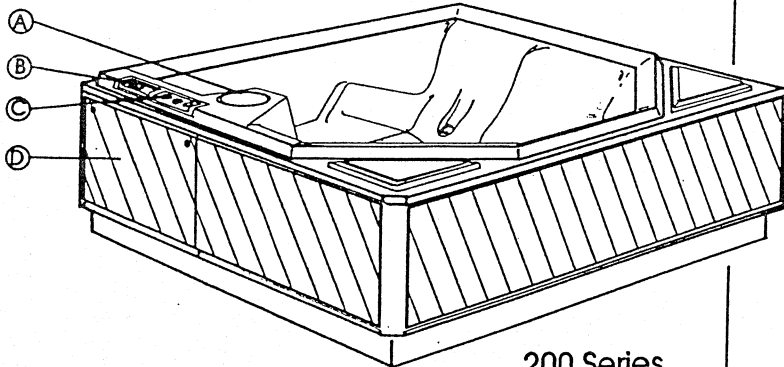

200 Series

- A. FILTER SKIMMER/WEIR DOOR** - Removes floating debris from the water surface, provides a water return path to equipment, and houses water filter element.
- B. SPA SIDE CONTROL PANEL** - Used to control temperature setting, pump for hydro jets, air blower for massaging bubble action, and light.
- C. AIR MIXTURE CONTROLS** - Increases or decreases air entering the hydro-massage jets (should be closed when heating.) If using an ozonator, check manufacturers instructions.
- D. EQUIPMENT PACK SERVICE PANEL** - Spa support system consisting of 2-speed pump, water heater, air blower, filter, and associated electrical controls (not shown).
- E. PEDESTAL LIGHTING (300 Series Only)** - Adds beauty and safety to your spa area. It will illuminate approximately 3' around the cabinet.

SPA INSTALLATION

BE SURE TO READ THE FOLLOWING INFORMATION BEFORE CONNECTING YOUR SPA TO AN ELECTRICAL SOURCE!

DANGER: RISK OF ELECTRICAL SHOCK. INSTALL AT LEAST 5 FEET FROM ALL METAL SURFACES.

(For all permanently connected units not provided with an integral disconnecting means.) The electrical supply for this product must include a suitably rated switch or circuit breaker to open all ungrounded supply conductors to comply with Section 422-20 of the National Electrical Code, ANSI/NFPA70-1987. The disconnecting means must be readily accessible but installed at least 5 feet (1.5 meters) from tub water.

OUTDOOR INSTALLATION

Keep the following factors in mind when installing your spa outdoors.*

1. Local codes pertaining to fencing.
2. Local electrical and plumbing codes.
3. View from your house.
4. Wind direction.
5. Exposure to sunlight.
6. Location in regard to trees (falling leaves and shade problems).
7. Dressing and bathroom location.
8. Storage area for maintenance equipment and chemicals.
9. Location to facilitate adult supervision.
10. Landscaping and nighttime lighting.
11. Easy access to equipment cabinet panels.
12. Power cord location and foot traffic.

*If your spa is installed outdoors, we recommend that you provide a concrete pad for the spa to rest on (8 x 8 x 4" thick level pad).

INDOOR INSTALLATION

1. Indoor spas promote high humidity, so a means of decreasing this humidity must be provided. This can be accomplished by using either ventilation fans or oversized dehumidifiers. Consult your dealer.
2. Floor drains should be provided to drain off water splashed from the spa which may cause walking hazards and/or water damage.
3. Floor area should be flat and non-skid.
4. Walls, ceilings, woodwork should be of materials capable of withstanding high humidity (redwood, cedar).
5. Be sure floor load bearing capacities are adequate to support the concentrated spa weight.
6. Spas should be double checked for leaks before taking inside to avoid possible water damage.
7. Indoor sunrooms are capable of maintaining high ambient temperatures which may effect the spa water temperature. It is not recommended that you operate your filter cycles for longer than 5 hours under these conditions.

GENERAL

Locate the spa on solid, level ground, foundation or flooring. Keep in mind the weight of the filled spa (in excess of 4,000 lbs. on some models). If you have any doubts about the load bearing ability of your chosen site, contact an architect, your building department or other knowledgeable authority. **It is important that the entire perimeter of the spa cabinet and the spa bottom are evenly supported.**

Should you install your portable spa below floor level you must provide room to allow access for servicing from above or below the floor. **Your spa must be installed to provide drainage for the electrical compartment.**

Because of equipment accessibility and drainage problems, the manufacturer recommends that you do not install below floor level.

NOTE: Access must be left for maintenance on the complete equipment side (both equipment cabinet panel and side fixed panel).

NOTE: Plumbing of any ozone unit is the responsibility of the dealer.

ELECTRICAL INFORMATION

CAUTION: RISK OF ELECTRICAL SHOCK. READ AND FOLLOW ALL INSTRUCTIONS

IMPORTANT SAFETY INSTRUCTIONS

Prior to performing any service to the spa package turn OFF ALL primary electric power at the main circuit breaker or disconnect panel.

All field electrical connections can be made by removing the front panel of the electrical control box. To gain access to the control box you must remove the equipment pack service panel.

All electrical connections to this spa package must be accomplished by a qualified electrician in accordance with the National Electric Code or the Canadian Electric Code and in accordance with any local electrical codes in effect at the time of installation.

All connections should be made in accordance with the wiring tag enclosed in the electrical control box or the wiring diagrams within this manual.

This equipment is designed to operate on 60Hz Alternating Current only, at a voltage of 120 or 240 volts as required.

Connections should be made using copper conductors only. The connecting wire and circuit breakers or fuses must all be sized to accommodate the Total Ampere load as specified on the equipment module data label.

(Cord-connected units with optional GFCI) Connect power cord only to a properly grounded dedicated receptacle.

(Cord-connected units) A pressure wire connector is provided on the surface of the control box inside the spa to permit connection of a bonding wire between this point and any metal equipment, metal enclosures of electrical equipment, metal water pipe or conduit within five feet of the unit as needed to comply with local requirements. The bonding wire must be at least a No. 8 AWG solid copper wire.

(Permanently-connected units) A green colored terminal (or a wire connector marked "G," "GR," "Ground," or "Grounding") is provided in the control

box. To reduce the risk of electric shock, connect this terminal or connector to the grounding terminal of your electric service or supply panel with a continuous green insulated copper wire equivalent to the circuit conductor supplying this equipment, but no smaller than No. 12 AWG. In addition, a second wire connector is provided for bonding to local ground points. To reduce the risk of electric shock, this connector should be bonded with a No. 8 AWG copper wire to any metal ladders, water pipes, or any metal within 5 feet of the tub.

(Permanently-connected units) A hole can be drilled in the pedestal or base of the unit to bring the conduit to the hole provided in the equipment compartment.

120 VOLT INSTALLATION

CONNECT TO GROUNDED TYPE RECEPTACLE ONLY

CORD CONNECTED - (OPTIONAL WITH G.F.C.I.)

Electrical Requirements (Model 80, 100 series) 120 Volts, 60Hz, Single Phase, 20amp., grounded receptacle.

All other models must have all electrical connections made by a qualified licensed electrician, in accordance with the National Electrical Code. Other appliances or electrical equipment cannot be used on this circuit.

Be sure to isolate the power cord from all foot traffic areas to prevent cord damage or tripping accidents. Route the cord through the hole in the side of the cabinet provided for this purpose.

PERMANENTLY CONNECTED

Electrical Requirements (200, 300 series models): 120 Volts, 60Hz, Single Phase, 30 amp., grounded receptacle.

Equipment modules wired for 120 volt operation require a 3 wire electrical service (line 1, black), (neutral, white) and (ground, green). Refer to terminal block diagram on pages 23 & 24.

240 VOLT INSTALLATION

Electrical Requirement: 240 Volts, 60Hz, Single-Phase, 50 amp., 4 wire service.

Units to be operated at 240 volts must have all electrical connections made by a qualified electrician in accordance with the National Electric Code, the Canadian Electrical Code or other local electrical codes in effect at the time of installation.

DO NOT RUN CONDUIT THRU THE VENT HOLES BELOW THE DOOR.

Equipment modules installed for 240 volt operation require a 4 wire, 50 amp., 240 volt subfeed in non-metallic pipe to the spa equipment compartment (line 1, line 2, neutral and ground). Refer to terminal block diagram on pages 23 & 24. Take precautionary steps to ensure that all procedures regarding the conversion information have been implemented. See pages 23 & 24.

START - UP PROCEDURES

First, follow recommendations for site location and electrical connection. **DO NOT TURN POWER ON** at this time. Fill spa with water to water line mark on Weir door.

The water level must be measured with no one in the spa. The space from the water to the top lip of the spa allows for the water to rise as people enter the spa without it overflowing. Operating the spa when the water level is low can damage the pump and heater and could cause a fire.

Careful attention must be paid to filling with water and bleeding air from the plumbing system every time the spa is drained.

1. Turn OFF all electrical power to the Equipment Pak.
2. Turn the thermostat to the OFF position.
3. Fill spa with water and check all plumbing connections for leaks before continuing.
4. With the thermostat in the OFF position, turn the Main Power ON.
5. The Pump and/or the Air Blower will start in one of the modes as described under spa side control functions.
6. Select Hydrotherapy mode, let the system run on this mode for a few minutes to bleed air out of the plumbing system. If the system does not prime after 4 minutes of running, turn the system off. See "Priming Spa", page 17. **DO NOT RUN DRY** for extended periods or you **WILL** permanently damage the pump.
IMPORTANT NOTE: Only after full water flow has been established should the thermostat be turned on.
7. Refer to Powerworks Control operating instructions.

NOTE: The Equipment Module must never be operated without water in the spa. Serious damage to the heater and/or pump could result.

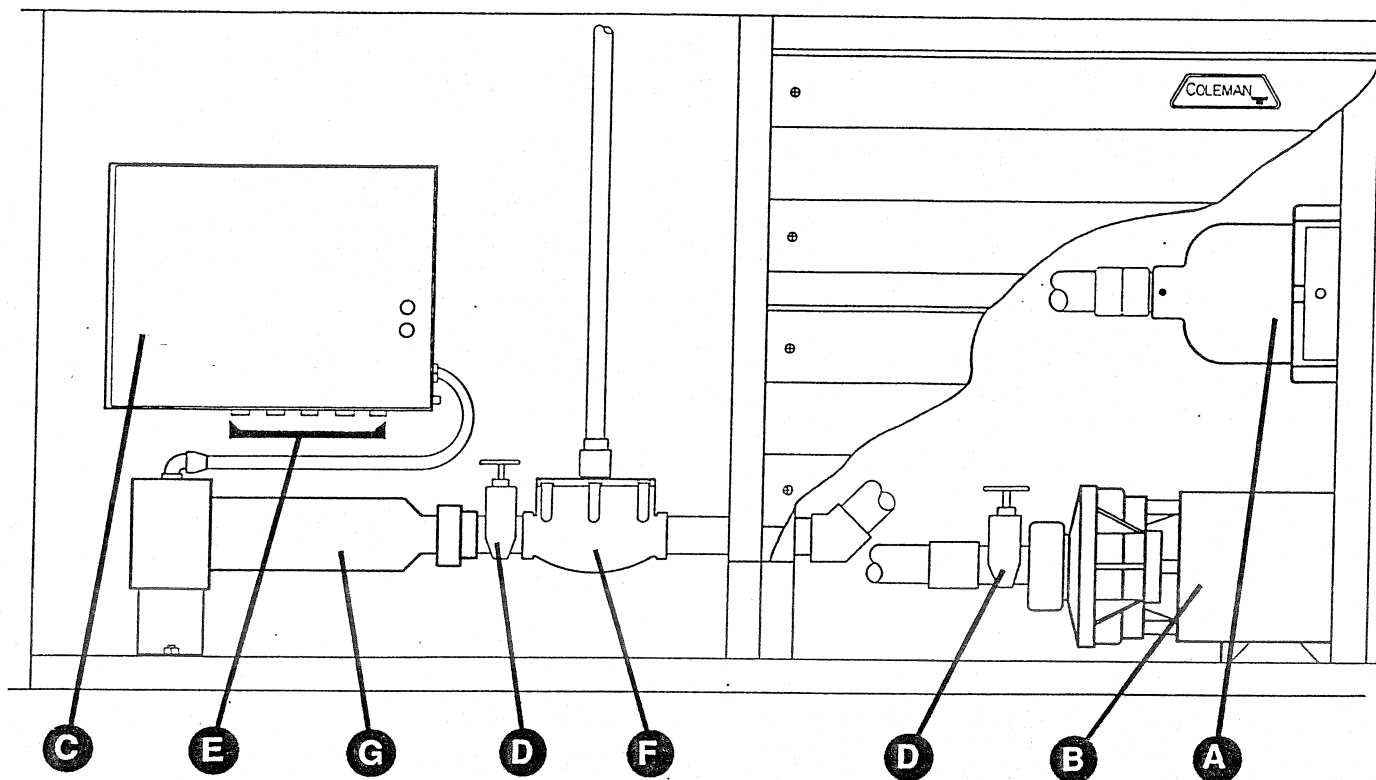

NO CONSUMER SERVICEABLE PARTS EQUIPMENT CONTROL PANEL

- A. AIR BLOWER** - Provides a large volume of air to the air holes in the floor and/or seat of the spa for a vigorous bubble action (located behind or inside compartment). Not available on Model 80 Spas.

NOTE: The heater will not operate during blower operation

NOTE: BLOWER TEMPERATURE - The temperature of the air from the blower is directly related to the ambient air temperature. Depending on the temperature, you may find that air from the blower feels either hot or cold. We recommend that you consider this and use the blower accordingly. A chart which outlines the average comfort zone considering ambient air temperature is located on page 9.

- B. TWO SPEED PUMP** - Low speed for efficient water circulation during filtration and heating; High speed for maximum action of the hydro jets. The pump

functions are activated by topside controls.

- C. MANUFACTURER'S IDENTIFICATION LABEL** - Contains important identification information for warranty service.
- D. SLICE VALVE** - (Service) Used to shut off water flow from the spa to the equipment pak while servicing. It should be open during normal operations.
- E. ELECTRICAL CONNECTIONS** - The electrical plugs for the unit connect here. All existing connections should be intact.
- F. JET SELECTOR VALVE** - (200 & 300 series spas)
See page 16.
- G. HEATER ASSEMBLY** - Thermostatically controlled and equipped with a high-limit safety shut-off. The high limit switch cannot be re-set until the temperature within the heater assembly drops several degrees. (See Powerworks Control Instructions to Reset) Should the high-limit switch trip repeatedly, the Equipment Module should not be operated until the problem has been corrected. Contact your local dealer to remedy this problem.

OPERATING INSTRUCTIONS

SPA SIDE CONTROL FUNCTIONS

TOP SIDE CONTROLS (Shown Below)

The top side controls activate the different models of operation, and depending on the model, the lights and temperature of the spa.

FUNCTION BUTTON/PUMP BLOWER BUTTON

Activates the modes of operation as described on the following pages. These functions are specific to the model and the electrical hookup.

LIGHT BUTTON (except model 80)

Activates the underwater light (and the pedestal lights on 300 series models only).

THERMOSTAT/TEMPERATURE SET

Controls the heater over a range of approximately 75 degrees to 104 degrees. Voltage and altitude may affect the accuracy of your thermostat.

AIR CONTROLS

Allows air into jets, for adjustable vigorous water action.

JET SELECTOR KNOB (300 and 200 series models)

Allows the choice of which jets will operate. See page 16.

	AMBIENT OUTDOOR TEMPERATURE	AIR CHANNEL TEMPERATURE	PERCEIVED SENSATION
	40°	70-80	COOL
BLOWER	60	90-100	LUKE WARM
COMFORT	70	100-110	WARM
ZONE	80	110-120	WARMER
	90	120-130	VERY WARM
	100	130-140	HOT

COMFORT ZONE - IDEAL AMBIENT AIR TEMPERATURE FOR OPERATING AIR BLOWERS

1) Temperatures BELOW this comfort range will cause the water to cool off rapidly. This wastes electricity, as the spa water will have to be reheated.

2) Temperatures ABOVE this comfort range can cause some discomfort due to your skin sensing the differential between the water and air temperatures. Some people are more sensitive than others and will feel discomfort at lower temperatures. The blower can be turned to low speed (Horizon Series) or off to avoid discomfort.

3) Very warm and hot temperatures may be perceived after about 10 minutes of air blower operation.

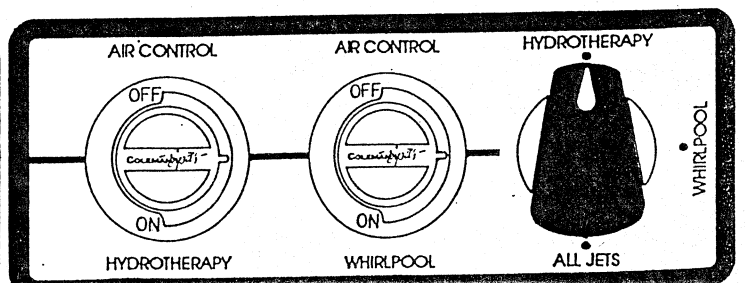
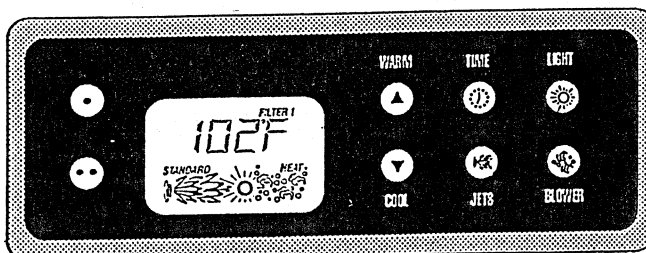
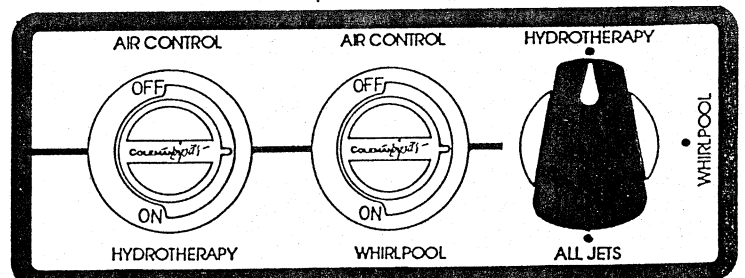
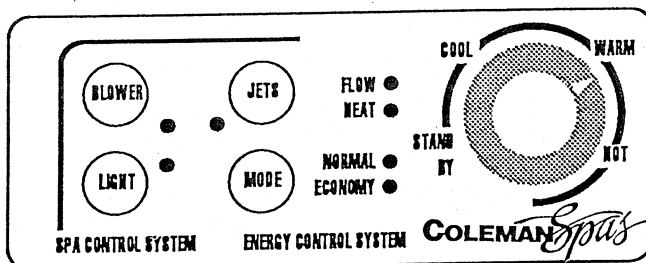

POWERWORKS CONTROL — PARK AVENUE — SPECTRUM

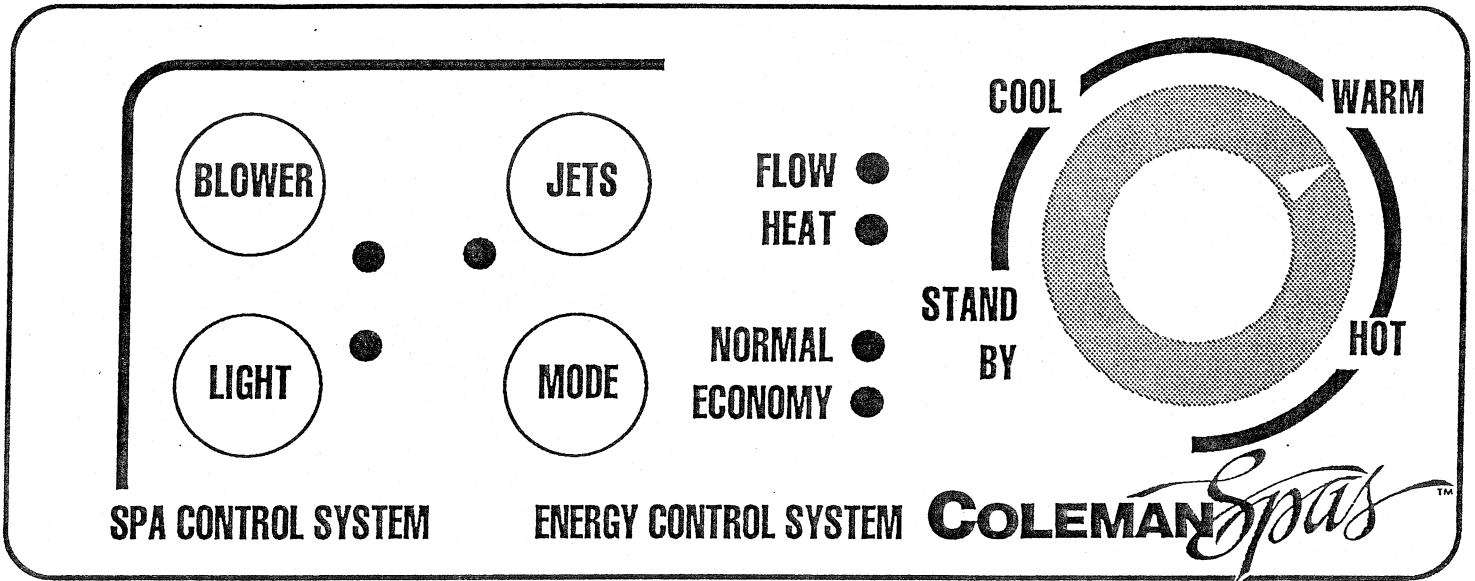

SPA CONTROL SYSTEM:

The Spa Control System activates the different modes of Spa Operation on the 100 and 200 series.

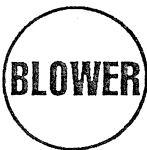

Blower: Press this pad to start and stop the blower for aeration from the spa seats. The blower will automatically stop after 30 minutes of operation. Press the pad again to restart the blower.

The blower will also automatically run for 20 seconds at the start of the filter cycle. (Note: Model 80 Spas are not equipped with a blower)



Light: Press this pad to turn the spa light on. The light will automatically turn off after 30 minutes of operation. (Note: Model 80 Spas are not equipped with a light)



Jets: Press this pad once to activate the high speed pump on the 100 Series. Press again to turn off the pump. The low pump may stay on when you press the button following the high speed pump mode due to Automatic Spa Control. (See next column)

On the 200 Series, with the pump off, the first press of the pad activates the low speed and the second press turns on the high speed.

Automatic Spa Control: The low speed pump will start automatically when the heater is turned on, when a filter cycle is activated or when a freezing condition is detected. If automatic activation occurs, the low speed pump cannot be turned off with the "Jets" pad; however, the high speed pump may be started. Whenever the pump is started it will automatically turn off after 30 minutes of operation.

ENERGY CONTROL SYSTEM:

Filtration: There are two filter cycles. The first will turn on two hours after the unit is plugged in or the circuit breaker is turned on. The second filter cycle will turn on twelve hours after the first filter cycle turns on. The filter cycles are factory set at three hours each.

Example:

- Spa is plugged in at 8 a.m.
- Filter cycle one: 10 a.m. - 1 p.m.
- Filter cycle two: 10 p.m. - 1 a.m.

The Filtration time may be adjusted by your authorized Coleman Spa Dealer. There are four cycle time lengths available: 2, 3, 4, or 5 hours. To reset your daily filtration cycles, you must turn off your circuit breaker and turn it back on two hours before your desired start time.

You can manually start a clean-up cycle following the use of your spa by turning on the jets. The pump will run for 30 minutes and then automatically shut off.

Energy Control Mode: Pressing the mode pad switches the spa operation to either the Normal Mode or Economy Mode.

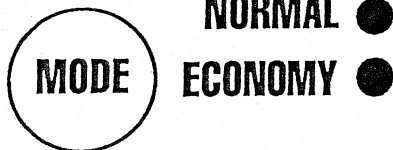

Normal Mode: In the Normal Mode the spa will be thermostatically heated to the set temperature 24 hours per day.

Economy Mode: In the Economy Mode the heater will only operate during the automatic filtration cycles or under freeze protection. (See freeze protection.)

Temperature Control: The spa water temperature is controlled by the knob on the panel. The standby setting is approximately 75°F., the maximum temperature setting is preset to 104°F.

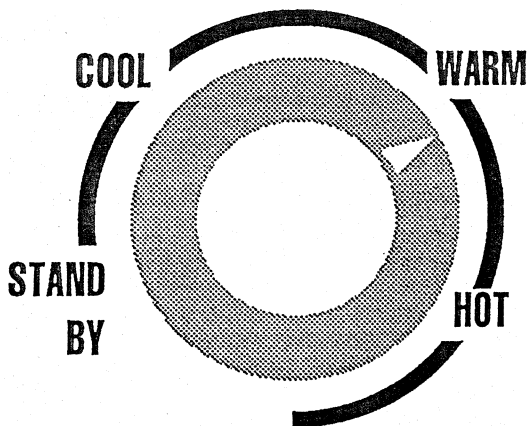

As the temperature knob is turned up and the low pump is activated, the Flow Light will turn on when a sensor detects adequate water flow for heater operation. Several seconds after the proper water flow is attained, the Heater Light will turn on indicating the system is calling for heat.

Safety Features: The Coleman Powerworks Control System has several safety features to protect the spa and equipment.

Freeze Protection: A sensor turns on the low pump when the water temperature in the equipment is below 40°F. In addition, while in the Economy Mode, a temperature sensor turns the heater automatically to thermostatic control if the spa water temperature drops to 20 F. below the set temperature.

FLOW ●
HEAT ●

Flow Sensor: This sensor activates the Flow Light on the control and allows the heater to turn on only if there is enough water flow. This prevents heater dry firing which can be caused from improper start up procedures or clogged pipes.

High Limit Sensor: There are two High Limit Sensors. The first Sensor detects spa water overheating (112°F). The equipment will not operate when the sensor has been activated. The Economy and Normal Lights will flash on and off. Once the water has cooled down, the High Limit indicator will automatically reset. If the spa overheats again, contact your dealer.

There is also a Heater High Limit Sensor set for 118°F., to detect overheating conditions in the heater which can be caused by restricted flow. Reset as you would the first.

POWERWORKS HORIZON CONTROL

The Ultimate Spa Controller Program

For initiating time setting, filter programming and panel lock.

Liquid Crystal Display
The "Information Center" of your spa.

Warm (up)
Sets the temperature of your spa warmer and sets the clock forward.

Time
Shows the time of day.

Lights
Turns the lights on and off.

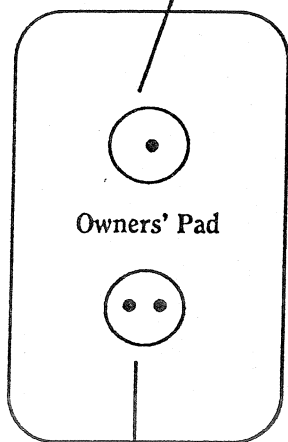

Owners' Pad

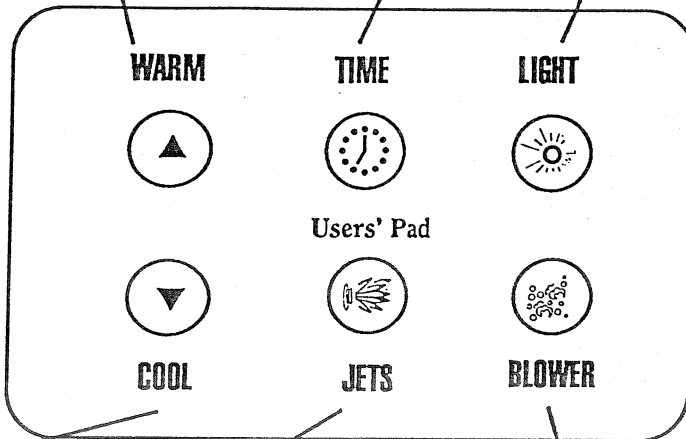
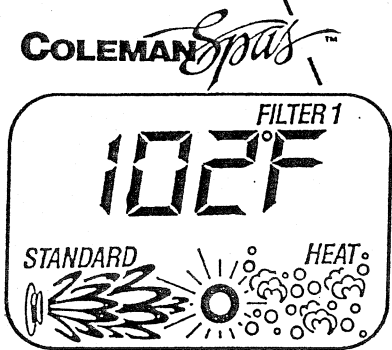

WARM

TIME

LIGHT

Users' Pad

COOL

JETS

BLOWER

Mode
Switches your spa from economy to standard mode and visa-versa.

Cool (down)
Sets the temperature of your spa cooler and sets the clock back.

Jets
Controls the two-speed pump.

Blower
Controls the two-speed blower.

1. Users' Pads

Temperature controls

When either of these pads are touched once, the LCD (liquid crystal display) will display the temperature which has been set, as well as the words "set heat." Each time either of these pads is pressed again, the set temperature will increase or decrease, depending on which pad is pressed. After 3 seconds, the LCD will automatically display the spa temperature. Note: There is a temperature lock feature. (See the lock section.)

Jets control

Touch this pad once to activate the low-speed pump, again for high speed, and again to turn off the pump. The low-speed pump will start automatically when the heater is turned on, when a filter cycle is activated, or when a freezing condition is detected. If automatic activation occurs, the low-speed pump cannot be turned off with the "jets" pad; however the high-speed pump may be started. Whenever the high-speed or low-speed pump is started with this pad, it will automatically stop after 30 minutes. This useful feature gives you a "clean-up" cycle after heavy use. Simply activate the low-speed pump when you leave the spa, for an additional 30 minutes of filtration.

Blower

Touch this pad to start the high-speed blower. Touch again for low-speed blower operation. The blower will automatically stop after 30 minutes of operation. NOTE: The heater will not operate while the blower is operating.

Lights

Touch this pad once to turn on the spa light; again to turn on the perimeter lights. Press the pad a third time and both the spa and perimeter lights will turn on. Both lights will automatically turn off after 30 minutes.

Time

Press to view time of day. Press again to view temperature. Current spa temperature display will automatically resume after five seconds.

2. Liquid Crystal Display

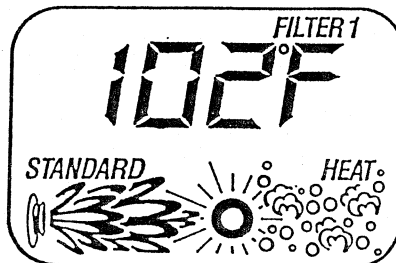

Continually shows operating status of the spa, as well as the various monitoring functions and programming information.

3. Owner's Pads







Program function: Initiates time setting, filter programming, and panel lock routines.



Mode function: Switches spa operation to either the economy or standard mode. In the economy mode, the spa will heat only during the filter cycles. In the standard mode, the spa will be automatically heated to the set temperature. This pad also resets the control in the rare instance of an overheat.

Setting the Time: This control has been specifically designed so that by simply connecting the spa to its properly grounded source and touching the mode (⊙) pad, the spa will function properly and safely at 100 degrees F. In this mode, all user pads will be completely functional. The spa will just about take care of itself. However, to fully utilize the unique capabilities of this control it is important to set the time of day properly. This is accomplished as follows:

Once the spa has been properly connected. Notice the "set time" message flashing on the screen.

Press  Then  Then  Or  After either pad is pressed once, time will advance or decrease automatically in one-minute increments. Press either pad again to stop the displays time-setting cycle.

Press 



Preset Filter Cycles: Now that the time has been set correctly, your spa will automatically filter itself for a 2-hour period every 12 hours. Whenever a filter cycle is active, this automatic filtering sequence is indicated by the following filter messages on the LCD screen:

Filter 1 The first filter cycle is automatically activated at 2:00 a.m. and operates the low-speed pump until 4:00 a.m. The heater will operate in the economy mode.

Filter 2 The second filter cycle is automatically activated at 2:00 p.m. and operates the low-speed pump until 4:00 p.m. The heater will operate in the economy mode.



Changing Filter and Heat Cycles:

If the present times are inconvenient, or a different duration is preferred, or you wish to leave the heater off during filtering, the following procedure can be used to change the automatic filter cycle settings.

Press  Time of day will be shown. Then Press  "Set time" message will appear on LCD.

Then Press  "Set Start Filter 1" message will appear. At this point, each time the program (⊙) pad is pressed, the filter-start time, the heater-enable status, and the filter-stop time will be indicated on the LCD screen.

When the filter-start or filter-stop times are displayed on the screen, Press  Or  to change the filter-start time up or down. Remember there are two filter cycles in a 24 hour period. Now press (⊙) To access your set heat mode.

When the "set heat" message is displayed, Press  Or  to set the center display to "on" or "off". The purpose of this function is to allow you to control your heater during the filtration cycles, while your spa control is set in the economy mode. You can set the heater to be "on" or "off" for either cycle. In the "on" position, the spa will warm to the set temperature during the filter cycles. In the "off" position, the heater will not be activated during the filter cycles. Now press (⊙) to set your filter stop-time.

When the filter-stop time is displayed on the screen, Press  Or  To change the filter-stop time up or down. After entering your filter set routine for filtration cycle one press (⊙) to adjust the second filter cycle.

To exit the filter-set routine, Press  and the LCD will display the current water temperature.

Note: To properly clean and maintain your spa, filtering time of at least four hours per day (total of both cycles) is recommended.

Panel Lock

To help prevent unauthorized use of your spa, this control has incorporated a unique panel locking system.

To lock the panel

Touch



The Center Display will read

LOC

Then



Then



The set lock pads must be pressed within 3 seconds to activate the lock. Within 3 seconds the center display will show the spa temperature along with the lock symbol. All the panel pads are now deactivated except the program pad which is used to initiate the unlock sequence.

To unlock the panel

Touch



Then



Then



When the panel lock is engaged, all automatic spa functions will operate normally. To unlock the panel, the three pads must be pressed in the correct sequence and within two seconds. When the last pad is pressed the lock symbol will disappear. All pads are now active.

Temperature Lock

To prevent unauthorized temperature adjustment of your spa water. While setting your spa water temperature, after you have pressed either ▲ or ▼, follow the instructions below to lock your set temperature.

To lock the temperature

Touch



LOCF

Then



Then



The set lock pads must be pressed within 3 seconds to activate the lock. Within 3 seconds the center display will show the spa temperature along with the lock symbol. The set temperature pads ▲ ▼ will be deactivated and when pushed, the set temperature will appear with a double arrow ⇕ next to it.

To unlock the temperature

Touch



Then



Then



To unlock the panel, the three pads must be pressed in the correct sequence and within two seconds. When the last pad is pressed the lock symbol will disappear. All pads are now active.

Center Display Messages

These are some of the messages you may see on the center display.

Message	Meaning
Pd	Battery backup Power has been cut off to the spa, and it is using its 20 minute battery backup to preserve its settings. The control panel will be disabled until power returns to the unit.
OH	Overheat protection (Spa is deactivated.) If a malfunction occurs and spa water reaches 112 degrees F., the system will completely shut down. In such a condition. DO NOT ENTER THE WATER. Turn off all power to the spa and contact your dealer or service organization.

Note:

If you set the low-speed pump to operate for extended periods of time (in economy mode), overheating may occur. If this happens, remove the spa cover and allow the water to cool to below 110 degrees F. Touch the Mode pad (☺) to reset the system. If the water is still hotter than the set temperature, touch the blower pad to cool the spa.

Message	Meaning
FLO	Flow switch A pressure switch has malfunctioned. Contact your dealer or qualified service organization.
COOL	Temperature set back If spa water is more than 20 degrees F. cooler than the temperature set point, the heater will automatically activate to provide freeze protection. This is also a normal spa function; no corrective action is necessary.
ICE	Freeze protection If a freeze condition is detected, the low-speed pump is automatically activated. This is also a normal spa function; no corrective action is necessary.
Sn 1	Open sensor (Spa is deactivated.) The high-limit temperature sensor is non-functional. This must be repaired only by a dealer or qualified service organization.
Sn 3	Open sensor (Spa is deactivated.) The main sensor is non-functional. This also must be repaired by a dealer or qualified service organization.

JET AND THERAPY CONTROL

AIR CONTROLS

The level of jet action is determined by the amount of air entering the therapy jets (should be closed when heating). The air controls, located on the lip of the spa, establish this level by increasing or decreasing the air to the jets.

HYDRO THERAPY JETS

The therapy jets, which are directional, return water into the spa from the equipment. A turbulent flow of water mixed with air will provide a concentrated body massage.

MICROSSAGE JETS

These rotating jets operate in conjunction with the therapy jets. Should the jet cease to spin there may be an obstruction which needs to be removed. Rotate the jet face counter clockwise and remove. Turn on the pump for a minute to clear the jet of any debris. Check the jet for hair or debris. Reinstall the jet face by turning clockwise until the tabs lock into place. Scaling can also cause jets not to run. Check water chemistry for high pH.

WHIRLPOOL JETS

(200 and 300 series only)
The whirlpool jets provide a high volume circular water flow.

JET SELECTOR KNOB

(200 and 300 series models)

Enables you to choose one of 3 therapy settings. Therapy setting controls a combination of therapy and microassage jets. The whirlpool setting controls 2 whirlpool jets or additional therapy and/or microassage jets depending on model.

The All jets position powers both the Hydro Therapy and whirlpool jets at the same time.

HYDROTHERAPY

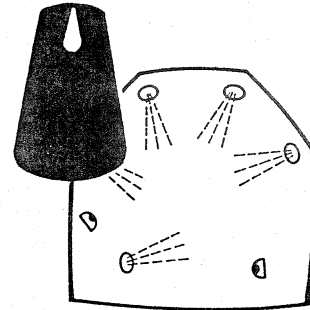

WHIRLPOOL

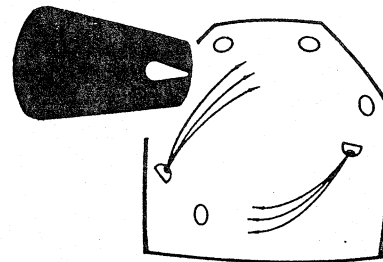

ALL JETS

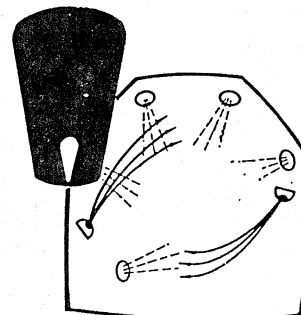

MAINTENANCE

SPA CABINET CARE

Your custom spa cabinet is made from quality handcrafted redwood. It has been coated with a seal and stain prior to spa assembly to preserve its appearance and help prevent weathering. Further wood protection requirements depend on spa location (indoors or outdoors, sun, shade, etc.), and local climate conditions. Re-treat with an appropriate product recommended by your authorized dealer upon installation and 3-4 times per year.

Cleaning the spa cabinet: Rinse dirt and dust regularly with clear water. To remove stubborn dirt, grime, and mild discoloration, wash with a mild detergent and warm water.

DRAINING SPA

Always turn the spa heater off when you drain your spa. Do not turn it back on until you have full flow coming out your jets for several minutes.

The water level in the spa must be kept at its normal level water line mark. Note: evaporation and splashing will cause the water level to drop.

Concentrations of impurities from evaporation, body oils, perfumes, and winds, etc., accumulate in the spa and cannot be filtered out. Consequently, it is necessary to drain your spa and refill it with fresh water every six to eight weeks or more often, depending on the amount of use.

To drain the spa, for 120 volt operation, unplug the cord. If your spa is wired for 240 volt operation, turn circuit breaker off.

100 Series

Drain access is behind the vertical redwood slat located on the side of the spa. The drain slat will have brass washers around the screws.

200/300 Series

Drain access is in the black pedestal base to the left of the equipment service panel. Simply remove the two screws holding the access panel on and pull the drain hose out.

Then attach a garden hose to the spa drain faucet and open the valve. Do not use the pump to drain the spa.

PRIMING SPA

Be aware that after draining and refilling your spa you may need to discharge air in the system in order for the pump to operate again. Should you experience an air-lock, you can remove the filter and insert a garden hose into the center hole and flush water through the system.

If power was turned off for draining, you must reset your filter cycles.

CLEANING

Your spa shell is formed by two layers of plastic material. The smooth top surface is made of tough long lasting acrylic and contains concentrated color. This acrylic surface is supported by a structural layer of fiberglass-reinforced polyester resin of substantial thickness. A chemical reaction occurs during manufacture that bonds these layers permanently into a hard, strong substance. A minimum amount of care and cleaning will keep your spa looking new for years.

To clean your spa, use a mild, non-abrasive liquid detergent, isopropyl alcohol, or commercially prepared spa cleaner. Do not use abrasive cleaners. Check with your dealer for approved cleaning materials, such as Lime-Away.

You can protect and restore the gloss to a dulled surface by using a product designed specifically for use on acrylic finishes, such as an acrylic polish.

Use a spa cleaner for residue and lime buildup at the water level of the spa surface. This can be applied to the acrylic surface with a soft cloth and wiped clean. Use small amounts to avoid polluting spa water. It may be necessary to lower the water level 2 to 3 inches before cleaning if heavily soiled at the waterline.

FILTER MAINTENANCE

The removable filter cartridge is located in the filter canister behind the skimmer. The filter should be inspected at least monthly during normal use, and more often when spa use is heavy.

Keep the filter clean! A clogged filter decreases both performance and water quality.

To clean the filter, simply follow these steps:

(Note: It is not necessary to drain the spa.)

1. Turn the pump off.
2. Remove round skimmer lid on top of spa.
3. Remove strainer basket.
4. Remove filter cartridge from the filter canister by grasping the handle on top, unscrewing it counterclockwise, and lifting out.
5. Soak and hose out filter cartridge, unless replacing with new cartridge.
6. Place filter cartridge back into filter canister, and screw back in clockwise with handle until snug. Do not overtighten. When the spa is empty the Weir door will block the filter canister. You must hold it out of the way when reinstalling the cartridge. When the tub is full of water the door will float so you will have easy access for installing the filter cartridge.
7. Replace strainer basket and skimmer lid.
8. Turn the pump ON.

In addition to performing normal filter maintenance, it will be necessary to occasionally remove oils that coat the filter reducing filter flow. To remove these oils, soak the cartridge in a plastic pail containing a commercial filter cleaning solution (available from your Coleman Spas dealer or most pool supply stores). Follow the manufacturer's instructions for use.

We suggest that you replace your filter cartridge yearly to maintain optimum performance.

WINTERIZING

In cold climates where freezing temperatures occur, special care is required to prevent the possibility of damage to the spa and equipment due to freezing.

If you plan on using your spa during cold months, be sure your pump and heater are in good working order. The spa shell has been insulated to provide efficient operation in cold weather areas.

SPECIAL NOTE: IF YOU DO NOT INTEND TO USE YOUR SPA DURING THE WINTER MONTHS AND THERE IS DANGER OF FREEZING, THE SPA MUST BE WINTERIZED! YOU MUST DO THE FOLLOWING:

1. Shut off all electrical power to the portable spa.
2. Drain spa of all water. If you cannot draw off all of the water (especially from hoses) R.V. antifreeze should be added to the remaining water. If antifreeze is used, it should be an inhibitor Propylene Glycol such as Dow Frost available through Dow Chemical Distributors.
3. Be sure to drain all drain hoses.
4. The filter should be drained, and cartridge removed and cleaned.
5. Check to see that there is no water in the heater element chamber and air blower elbow.
6. Clean your spa as per previous maintenance instructions.
7. Cover your spa with a waterproof, water-shedding, impenetrable cover.
8. For further information on blowing out the plumbing lines and winterizing procedures, contact your local dealer.

NOTE: If you elect not to drain your spa and the temperature is going to be below freezing for extended periods of time, especially 0 and sub zero, it is best to operate the spa heater at high temperature.(90°-100°F) If the tub is not going to be used and kept in the 100°F range you may have problems if your power goes out. It is wise during these bad weather periods to set the thermostat higher. This will keep the spa water from freezing quickly if you have a power failure.

LIGHT BULBS

The Spa light bulb is serviceable from outside the spa. You must remove the redwood panel and insulation closest to the light. Once the panel is removed, look for the bulb holding bracket and pull bracket towards you to change the bulb.

Perimeter light bulbs (300 series only) are also serviced by removing the redwood panel and foam insulation. Lift the light socket upward from the holding bracket to gain access to the bulb.

PROBLEM SOLVING GUIDE

PROBLEM	USUAL CAUSE	SOLUTION
1. System not operating.	A. House circuit breaker tripped or in OFF position.	A. Reset circuit breaker on home breaker panel.
	B. Power cord not connected to outlet.	B. Connect power cord to outlet.
2. Heater not functioning.	A. Heater mode not selected.	A. Refer to temperature and heater control instructions on pages 11 & 13
	B. No power to heater.	B. Check house circuit breaker.
	C. Thermostat set lower than water temperature.	C. Set to desired temperature.
	D. High limit safety switch tripped.	D. Refer to high limit instruction on pages 11 & 15. If high limit problems continue after resetting contact your dealer.
	E. Heater not operating.	E. Contact dealer.
3. Water not clean.	A. Clogged or blocked floor suction or skimmer.	A. Clean floor suction/skimmer.
	B. Filter clogged (dirty).	B. Clean or replace.
	C. Poor water chemistry.	D. See "Chemical Treatment" section.
	D. Insufficient filtering time.	D. Run filtration mode longer. Contact dealer.
	E. Improper maintenance.	E. See maintenance section.
	F. High content of solids in water.	F. Use clarifier or drain and refill spa.
4. Abnormal water usage.	A. Excessive evaporation and/or splashing.	A. Use spa cover.
5. Overheating.	A. High ambient temperature.	A. See page 5, #7 Indoor Installation
6. Low water flow from jets.	A. Operating in FILTER mode-low speed	A. Select Hydro Therapy or Whirlpool hi speed pump
	B. Clogged or blocked suction or skimmer.	B. Clean floor suction/skimmer.
	C. Dirty filter.	C. Clean or replace.

PROBLEM SOLVING GUIDE

PROBLEM	USUAL CAUSE	SOLUTION
7. No water flow from jets.	A. Pump not primed	A. See priming section - Page 17
	B. Unit not plugged in.	B. Plug unit in.
	C. House circuit breaker tripped, no power to system.	C. Reset circuit breaker at home panel.
	D. Faulty pump or motor.	D. Contact dealer.
8. Noisy pump and motor.	A. Clogged floor suction or skimmer.	A. Clean floor suction/skimmer.
	B. Low water level.	B. Add water to normal water level (6" below lip).
	C. Damaged or worn motor bearings.	C. Contact dealer.
9. Water leakage from under spa.		A. Contact dealer.
10. No air flow from jets.	A. Air control not open.	A. Open control.
	B. Jet nozzle not seated properly.	B. Check jet nozzles.
	C. Jet nozzle missing.	C. Inspect jets.
11. Motor will not operate.	A. House circuit breaker tripped or in OFF position.	A. Reset circuit breaker.
	B. Improper or defective wiring or electrical supply.	B. Contact dealer.
	C. Thermal Overload Protection switch tripped.	C. Auto reset after motor has cooled. Contact dealer if motor continues to cycle.
12. Blower motor will not operate.	A. OFF mode selected.	A. Check selection.
	B. House or panel mounted circuit breaker tripped or in OFF position.	B. Reset circuit breaker on Equipment Pak face on Home circuit breaker panel.
	C. Defective Thermal overload switch inside motor.	C. Contact dealer.
13. Black powder film around water line.	A. Wearing in of blower brushes.	A. Will disappear after use.

SPA SOAKING GUIDELINES

1. Persons with heart disease, diabetes, high or low blood pressure or any serious illness, and pregnant women should not enter a spa without prior consultation with their doctor.
2. People with skin, ear, genital or other body infections, open sores or wounds should not use the spa because of the possibility of spreading infection.
3. Before entering, look at the water in your spa. If there is cloudiness or foaming, or if a strong chlorine smell is present, the water needs treatment. Soaking in such water greatly increases your chances of getting a skin rash (pseudomonas). Be sure to maintain the water properly. Ask your Authorized Coleman Spas Dealer for guidance.
4. Shower with soap and water before and after using the spa. Showering before use washes away many of the common skin bacteria, and removes lotions, deodorants, creams, etc. Perspiration and lotions will reduce the effectiveness of the disinfectant and lessen the ability of the filter to work efficiently.
5. Enter the spa slowly and cautiously. Be careful of your footing, and allow your body to gradually get used to the water temperature. Leave slowly as well, because your leg muscles may be sufficiently relaxed to make you a bit unsteady, and you may become lightheaded.
6. Soaking for too long makes some people nauseous, dizzy, lightheaded or faint. **DON'T SOAK IN 104°F (40°C) WATER.** If you wish to soak for a longer period of time in high temperatures, leave the spa after 15 minutes, shower, cool down and then return for another brief stay. In lower temperatures (e.g. 98.6°F - normal body temperature) most people can comfortably and safely soak for longer periods at one sitting. If you have any questions about what's right for you and your family, consult with your doctor.
7. Keep an accurate thermometer in the spa at all times to monitor the water temperature. Be sure you check the water temperature before and while in the spa.
8. Never use the spa while under the influence of alcohol.
9. With any drug or medication, consult with your doctor about potential harmful effects from combined use of the drug and hot water soaking.
10. Never use the spa when you are alone, for safety's sake.
11. Never allow children to use the spa unsupervised.

WATER TESTING AND CHEMICAL TREATMENT

Water chemistry is critical in a spa system much more so than in an ordinary swimming pool. The combination of high temperature and small volume of water means that the chemical balance must be watched carefully, which is why a chemical start up kit should be purchased from your Coleman Spas dealer. The instructions should be followed routinely; ignoring them may damage or corrode your support system equipment. Keep your chlorine residual at 3.0 to 5.0 parts per million. **Chlorine tests should be done daily with your test kit (more frequently with heavy usage).**

The pH balance should be maintained between 7.2 and 7.6, and is adjusted by the addition of pH up or pH down. We do not recommend the use of muriatic acid in your spa because of its corrosive effects on the nonporous surface of your spa and its metal parts. If you must use acid to correct the pH, use only the dry type and dissolve it in water prior to adding it to the water in the spa. **NEVER MIX TWO CHEMICALS TOGETHER. NEVER STORE ANY CHEMICALS IN THE EQUIPMENT COMPARTMENT.**

RECOMMENDED LEVELS-SPAS

pH: 7.2-7.8 (Ideal- 7.4-7.6)

Total Alkalinity: 80-100 ppm Ideal for dichlor, trichlor, bromine

Free Available Chlorine: 3.0-5.0 ppm

Bromine Residual: 3.0 - 5.0 ppm

Total Dissolved Solids: 1,000-2,000 ppm

HOT WATER GUIDE

PROBLEM	CAUSE	SOLUTION
Cloudy water	<ul style="list-style-type: none"> Inadequate filtration/dirty filter Excessive oils/organic mater Improper sanitation/bacteria High pH and/or high alkalinity Suspended particles/organic matter High total dissolved solids(TDS) 	<ul style="list-style-type: none"> Check to make sure the filter is running properly/ Clean filter with a filter cleaner or degreaser. Shock the spa with a chlorine or bromine sanitizer/ shock or other shock treatment product. Increase sanitizer level to balance water and shock if needed. Adjust pH; add appropriate sodium bisulfate product. Use clarifier Depending on the severity-drain the spa to half and refill; or drain the spa completely, clean and refill.
Water Odor	<ul style="list-style-type: none"> Excessive organics/too many chloramines insufficient free available chlorine Improper sanitation Inadequate filtration Low pH 	<ul style="list-style-type: none"> Shock the spa with a chlorine or bromine sanitizer/shock or other shock treatment product. Increase sanitizer level to balance water; shock if needed. Check to make sure the filter is running properly/ Clean filter with a filter cleaner or degreaser. Raise pH with sodium bicarbonate product. If metals present, add chelating agent.
Chlorine Odor	<ul style="list-style-type: none"> Too man chloramines-insufficient free available chlorine Low pH 	<ul style="list-style-type: none"> Shock the spa with a chlorine sanitizer/shock or non-chlorine shock treatment. Adjust pH; raise pH with sodium bicarbonate product.
Bromine Odor/ Yellow Water	<ul style="list-style-type: none"> Low pH 	<ul style="list-style-type: none"> Adjust pH; raise pH with sodium bicarbonate product.
Musty Odor	<ul style="list-style-type: none"> Bacterial or algae growth 	<ul style="list-style-type: none"> Shock the spa with a chlorine or bromine sanitizer/ shock or equivalent shock treatment product. If problem is visible drain, clean, refill and balance spa.
Foaming/Scum Ring Around the Tub	<ul style="list-style-type: none"> Build up of body oils, lotion and chemicals resulting from soap or detergent 	<ul style="list-style-type: none"> Add defoamer; or drain and refill.
Algae	<ul style="list-style-type: none"> pH Imbalance Low free chlorine or bromine concentration 	<ul style="list-style-type: none"> Adjust pH Shock with a chlorine or bromine sanitizer/shock or other shock treatment product.
Eye Irritation	<ul style="list-style-type: none"> Low pH Insufficient free available chlorine 	<ul style="list-style-type: none"> Raise pH with sodium bicarbonate product. Shock with a chlorine sanitizer/shock or other shock treatment product.
Skin Irritation/Rash	<ul style="list-style-type: none"> Unsanitary/polluted water Soaking too long Water temperature too high 	<ul style="list-style-type: none"> Keep recommended sanitizer residual at all times; superchlorinate or use a non-chlorine shock treatment. Soak for smaller intervals, such as 15 minutes. Reduce water temperature.
Scale	<ul style="list-style-type: none"> Too much calcium dissolved in water-pH and total alkalinity too high 	<ul style="list-style-type: none"> Add a scale control product. Adjust total alkalinity and pH levels by adding the appropriate sodium bisulfate product; with concentrated scale deposits-drain the spa, scrub the scale off, refill the spa and balance the water.
Erratic pH Test Results/ Unusual pH Test Color	<ul style="list-style-type: none"> Sanitizer level too high Old pH indicator dye 	<ul style="list-style-type: none"> When the sanitizer level is below 5 ppm, test the pH. Replace the pH indicator dye.
Sanitizer Dissipating Too Rapidly	<ul style="list-style-type: none"> Excessive organics in water Temperature too high Low pH Low pH Corrosion of Metal Fixtures Low calcium hardness Low total alkalinity 	<ul style="list-style-type: none"> Increase shock dosage; add sanitizer; have bathers shower before entering spa. Reduce temperature. Raise pH with sodium bicarbonate product. Use a chelating agent if metals are present. Keep proper pH level (7.2 to 7.6 to 7.8). Use a chelating agent if metals are present. Maintain minimum 150-200 ppm calcium hardness. Use a chelating agent if metals are present. Maintain proper alkalinity for type of sanitizer used.

100/200 SYSTEM WIRING DIAGRAM 09/90

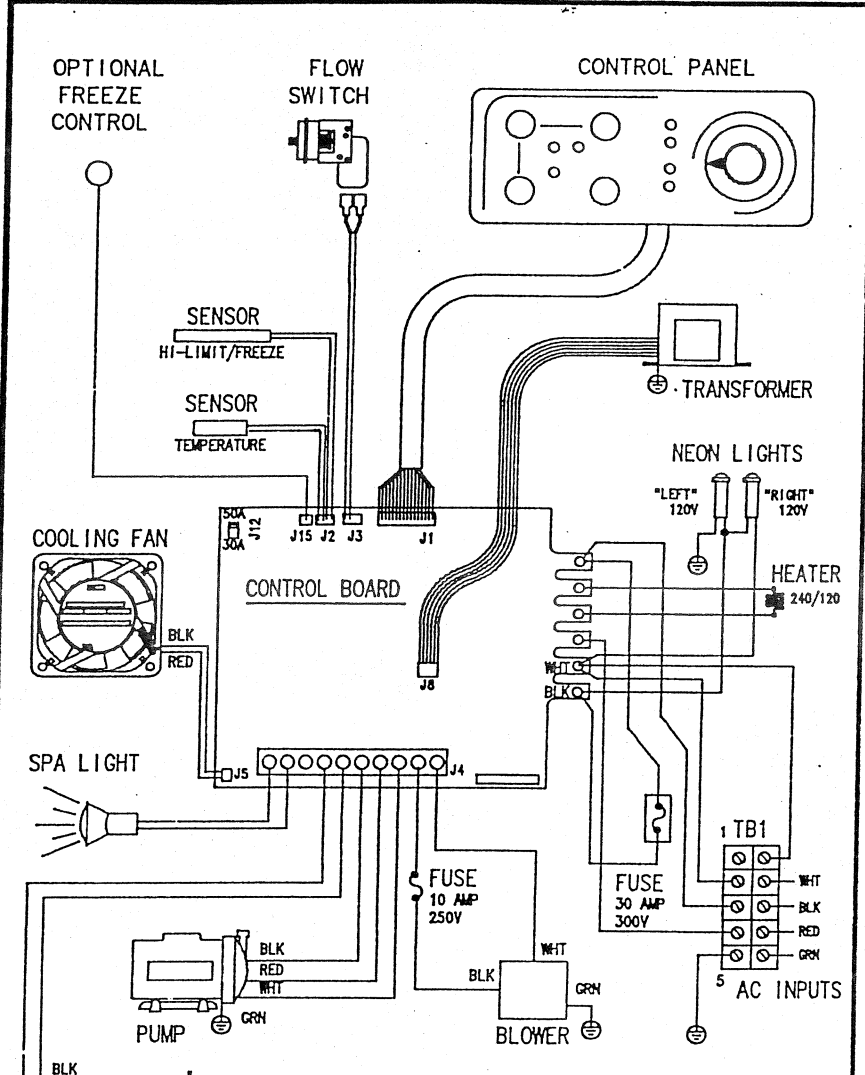

BOTH NEON LIGHTS MUST BE ON TO SHOW PROPER POLARITY OF POWER SUPPLY
 RIGHT LIGHT "ON", LEFT LIGHT "OFF": "NO CHASSIS GROUND"
 LEFT LIGHT "ON", RIGHT LIGHT "OFF": "(WHT) POWER LEAD IS NOT CONNECTED"
 LEFT & RIGHT LIGHT BOTH OFF: "(BLK) POWER LEAD IS NOT CONNECTED"
 OR "SYSTEM FUSE BLOWN" OR "NO POWER"

HEATER CONVERSION DIAGRAM 240V TO 120V

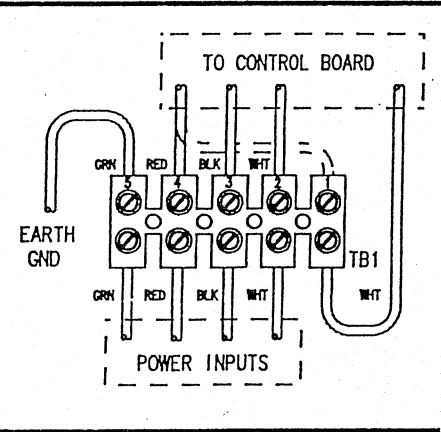

- CONVERSION INSTRUCTIONS:**
1. CONVERSION MUST BE PERFORMED BY A QUALIFIED, LICENSED ELECTRICIAN.
 2. DISCONNECT POWER.
 3. MOVE RED WIRE (TB1-4) TO (TB1-1) AS INDICATED BY DASHED LINES.
 4. MOVE JUMPER J12 TO 30 AMP POSITION

300 SYSTEM WIRING DIAGRAM

09/90

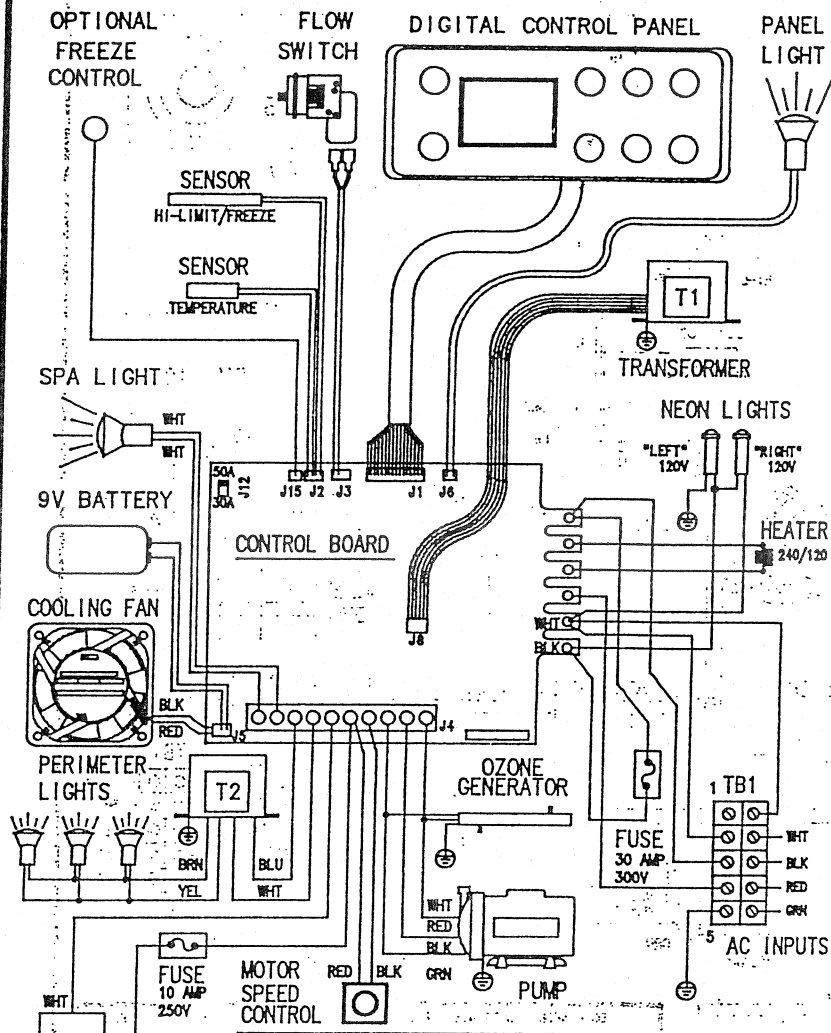

BOTH NEON LIGHTS MUST BE ON TO SHOW PROPER POLARITY OF POWER SUPPLY

RIGHT LIGHT "ON", LEFT LIGHT "OFF":	"NO CHASSIS GROUND"
LEFT LIGHT "ON", RIGHT LIGHT "OFF":	"(WHIT) POWER LEAD IS NOT CONNECTED"
LEFT & RIGHT LIGHT BOTH OFF:	"(BLK) POWER LEAD IS NOT CONNECTED" OR "SYSTEM FUSE BLOWN" OR "NO POWER"

HEATER CONVERSION DIAGRAM 240V TO 120V

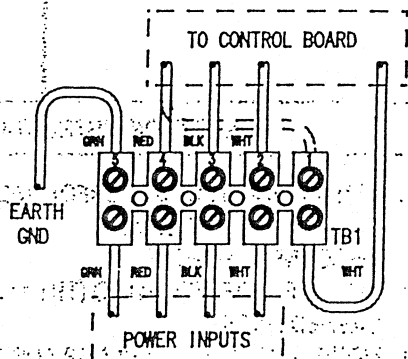

CONVERSION INSTRUCTIONS:

1. CONVERSION MUST BE PERFORMED BY A QUALIFIED, LICENSED ELECTRICIAN.
2. DISCONNECT POWER.
3. MOVE RED WIRE (TB1-4) TO (TB1-1) AS INDICATED BY DASHED LINES.
4. MOVE JUMPER J12 TO 30 AMP POSITION

LIMITED WARRANTY SUMMARY

Please see the Warranty Card included with your product for complete warranty information.

Coleman Spas, Inc. provides a limited warranty to our customers. It applies to the spa structure, surface, most plumbing, the pump, heater, blower, and controls.

The warranty has limitations. These include improper maintenance, improper installation, misuse, abuse, accident, fire, normal wear and tear or improper water maintenance. Unauthorized modifications of the spa may void the warranty. Replacement costs associated with transportation, removal, and reinstallation are the sole responsibility of the spa owner.